

## FAILURE BEHAVIOUR OF RESISTANCE SPOT WELDED LOW CARBON STEEL IN TENSILE-SHEAR AND COACH-PEEL TESTS: A COMPARATIVE STUDY

Majid Pouranvari<sup>1\*</sup>, Pirooz Marashi<sup>2</sup>

<sup>1</sup>Young Researchers Club, Islamic Azad University, Dezful Branch, Dezful, Iran

<sup>2</sup>Mining and Metallurgical Engineering Department, Amirkabir University of Technology, Tehran, Iran

Received 09.07.2009

Accepted 28.09.2009.

### Abstract

In this paper, behaviour of resistance spot welded joint was studied under tensile-shear and coach-peel loading condition. Failure modes of resistance spot welds, pullout and interfacial, were investigated based on experimental observation. Optical micrographs of the cross sections of spot welds in shear-tensile and coach peel specimens before and after failure are examined to understand the failure mechanism. Results showed that there is a critical fusion zone size to ensure pullout failure mode. The experimental results showed that in pullout failure mode during shear-tensile test, necking is initiated at nugget circumference in the base metal and then the failure propagates along the nugget circumference in the sheet to final fracture, while pull out failure during coach peel test occurred by crack initiation and propagation near the weld nugget/HAZ boundary. The critical fusion zone size required to ensure pullout failure mode during tensile shear test was larger than that of during coach-peel test.

*Key words:* Resistance spot welding, coach-peel test, tensile-shear test, failure behaviour

### Introduction

Resistance spot welding (RSW) is considered as the dominant process for joining sheet metals in automotive industry. Vehicle crashworthiness, which is defined as the capability of a car structure to provide adequate protection to its passengers against injuries in the event of a crash, largely depends on the integrity and mechanical performance of spot welds [1, 2]. Overload failure mode of spot welds is a qualitative measure of the weld reliability. Generally, spot welds fails in two modes: interfacial and

---

\* Corresponding author: M. Pouranvari [mpouranvari@yahoo.com](mailto:mpouranvari@yahoo.com)

pullout [3, 4]. In the interfacial mode, failure occurs via crack propagation through fusion zone (weld nugget), while in the pullout mode, failure occurs via complete (or partial) nugget withdrawal from one sheet.

Failure mode of RSWs can significantly affect their carrying capacity and energy absorption capability. Spot welds that fail in nugget pullout mode provide higher peak loads and energy absorption levels than spot welds that fail in interfacial fracture mode. To ensure reliability of spot welds during vehicle lifetime, process parameters should be adjusted so that pullout failure mode is guaranteed [5-7].

Due to the weld thermal cycle a heterogeneous structure will be created in spot weld and the region around it. Spot weld and its surrounding area can be divided into three zones: (i) Fusion zone (FZ) or weld nugget (WN), (ii) Heat affected zone (HAZ), (iii) Base metal (BM).

Geometrically, spot weld causes an external crack at the joint. Also, electrode forces create an indentation and therefore stress concentration in the sheet. These two factors (microstructural and geometrical changes) reduce load capacity of the joint compared with the BM. Vehicle crashworthiness depends on the weld structural integrity. Therefore, understanding spot welds mechanical behavior under different loading conditions is important.

The aim of the present work is to investigate failure modes and failure behavior of resistance spot welds under two loading conditions: The tensile-shear test and coach-peel test.

## Experimental

A 1.5 mm thick uncoated low carbon steel of the type used in automotive industry was used in the investigation. The chemical composition of the investigated steel is given in Table 1. Spot welding was performed using a 120 kVA AC pedestal type resistance spot welding machine, controlled by a PLC. Welding was conducted using a 45-deg truncated cone RWMA Class 2 (Cu-Cr-Zr) electrode with 7-mm face diameter. In all of the experiments, electrode pressure, squeeze time, welding time and holding time were kept constant at 4 bars, 45, 12 and 15 cycles, respectively. Welding current was changed from 10 to 12.5 kA. The aim of this experiment set is investigation of the effect of physical weld attributes (more importantly weld fusion zone size) on the weld performance.

*Table 1. The chemical composition of the investigated steel (%wt)*

C	Mn	Si	S	P	Fe
0.04	0.21	0.03	0.012	0.008	Base

The tensile-shear and coach-peel specimens used in the present investigation are shown in Figures 1a and 1b, respectively. Static mechanical tests were performed at a cross head of 2 mm/min with an Instron universal testing machine. The peak load and the failure energy were extracted from the load displacement curve.

Samples for metallographic examination were prepared using standard metallography procedure. Optical microscopy was used to examine the microstructures and to measure physical weld attributes. Micrographs of cross section of failed spot welds were examined in order to understand failure mechanism.

Vickers microhardness test was performed along interfacial line and 50 microns above weld centerline using 100 g load on a Shimadzu microhardness tester.

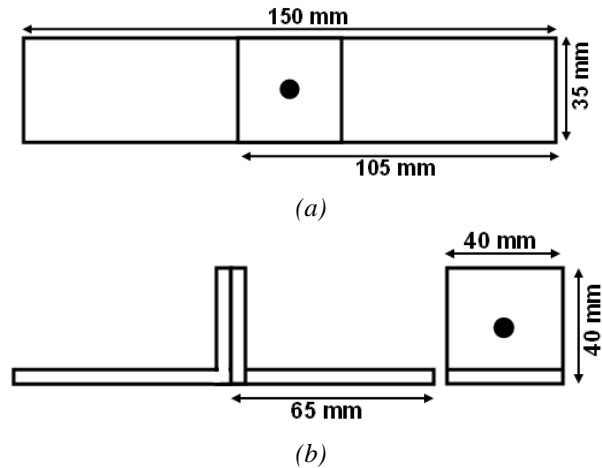

Figure 1 Dimensions of specimens for a) tensile-shear test and b) coach-peel test.

## Results and discussion

### *Microstructure and hardness profile of the joint*

Figure 2 shows a typical macrostructure of low carbon resistance spot welded joint. As can be seen, the joint region consists of three distinct structural zones:

- i) Fusion Zone (FZ) or weld nugget (WN) which is experienced melting and resolidification during thermal cycle of welding.
- ii) Heat Affected Zone (HAZ) which is experienced solid state microstructural alterations during thermal cycle of welding.
- iii) Base Metal (BM) which is remained unaffected during welding process.

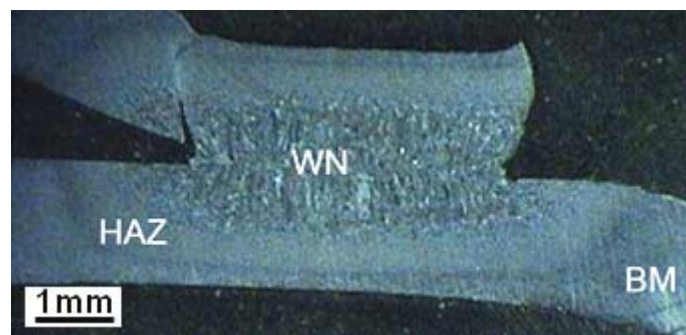

Figure 2 Macrostructure of low carbon resistance spot weld (welding current of this sample is 11.5 kA)

Fusion zone size is the most important governing parameter for determination of spot weld mechanical properties. Table 2 shows the effect of welding current on the fusion zone size. As can be seen, increasing welding current increases the fusion zone size due to increasing heat input.

Table 2 Effect of welding current on the fusion zone size

Welding current (kA)	10	10.5	11	11.5	12	12.5	13	13.5	14
FZ size (mm)	4.5	4.7	5	5.5	6.1	6.3	6.5	7.2	7.4

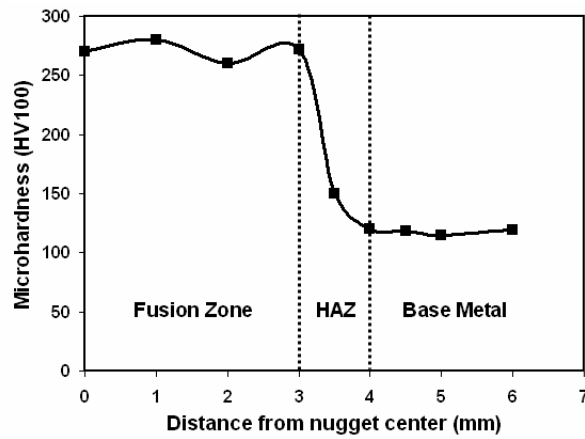
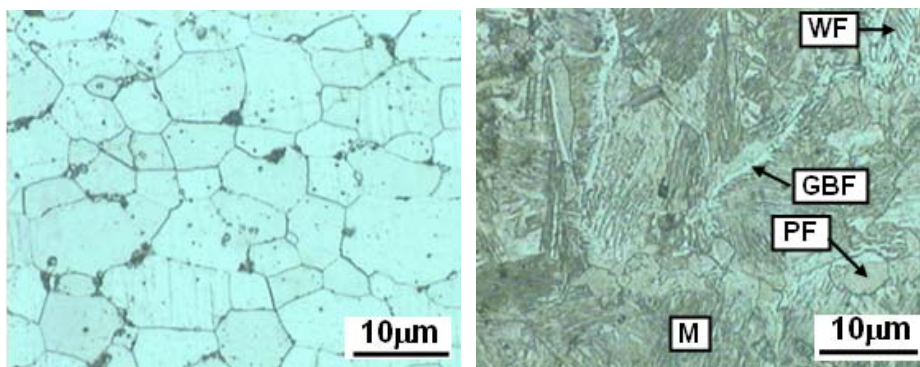

Figure 3 Typical hardness profile of low carbon resistance spot welds

Figure 3 shows a typical hardness profile of the RSW joint. Weld nugget hardness is about 2.5 times of the value of base metal. As shown in Fig. 4a, the microstructure of base metal used in this investigation is ferritic with a small amount of  $Fe_3C$ . Fig.4b shows the microstructure of weld nugget, which is mainly consisted of martensite.



(a)

(b)

Figure4 Microstructures of the a) base metal and b) fusion zone, M: Martensite, PF: Polygonal ferrite, GBF: Grain boundary ferrite, WF: Widmanstätten ferrite (welding current of this sample is 11.5 kA)

Some amount of grain boundary phases such as proeutectoid (grain boundary ferrite) and Widmanstätten ferrite, and polygonal ferrite are also present in the weld nugget microstructure. Despite the low carbon content of the base metal, martensite phase was formed due to high cooling rate of RSW process. Weld fusion zone microstructure of low carbon steel RSWs depends on chemical composition of the sheet and cooling rate. Gould et al. [8] proposed a simple analytical model predicting cooling rate during resistance spot welding. According to this model, cooling rate for 1.5 mm thickness is about  $4000 \text{ Ks}^{-1}$ . Presence of water cooled copper electrodes and their quenching effect as well as short welding cycle can explain high cooling rates of RSW process. Such high cooling rates can explain martensite formation in the weld nugget of a low carbon steel resistance spot weld.

#### *Pullout failure mechanism of tensile-shear test specimen*

Two types failure mode were observed during the tensile-shear test of low carbon resistance spot welds: interfacial and pullout failure mode, as shown in Figure 5.



Figure 5 Failure modes of spot welds during tensile-shear test a) interfacial and b) pullout failure mode

Figure 6 shows a simple model describing stress distribution at the interface and circumference of a weld nugget during the tensile-shear test. Shear stresses are dominant at the interface. At the nugget circumference, stresses are shear tensile at position T and shear compression at position C.

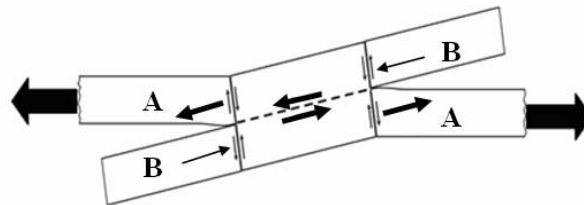

Figure 6 A simple model describing stress distribution at the interface and circumference of a weld nugget during the tensile-shear test.

In pullout failure mode, when there is certain amount of rotation, the tensile stresses formed around the nugget cause plastic deformation in sheet thickness direction. Finally, necking occurs at T sites as tensile force increases. These T sites are located in HAZ or in the BM. Necking does not occur in B sites because normal stresses are of compression type in these sites. This necking is not equal in both sheets. The stress concentration caused by the uneven necking in the two sheets leads to the failure of spot weld from one sheet. If the necking area is continually stressed, the nugget will eventually shear off from the other sheet.

In order to understand the failure mechanism, micrographs of the cross sections of the spot welded joints after tensile-shear are examined by optical microscopy. Figure 7 shows macrograph of fracture surface of a spot weld which failed at pullout mode. The failure of the spot weld appears to be initiated near the middle of the nugget circumference, and then propagated by necking/shear along the nugget circumference until the upper sheet is torn off.

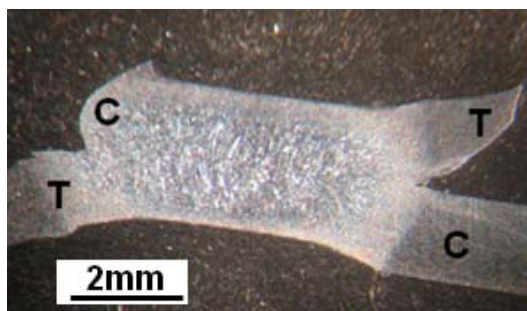

Figure 7 A typical macrograph of fracture surface cross section of spot welds which failed via pullout failure mode during tensile-shear test. T: Subjected to tensile stress; C: Subjected to compressive stress (welding current of this sample is 12 kA)

Necking location in tensile-shear test is dictated by hardness profile. As can be seen, necking is initiated at base metal, which its low hardness in comparison with HAZ and fusion zone can provide a preferential location for necking during the tensile-shear test. Therefore, it can be concluded that the strength of the spot welds in TS test is dictated by base metal strength rather than HAZ or fusion zone.

#### *Pullout failure mechanism of coach-peel specimens*

Two types failure mode were observed during the coach-peel test of low carbon resistance spot welds: interfacial and pullout failure mode, as shown in Figure 8.

In order to understand the failure mechanism, micrographs of the cross sections of the spot welded joints after coach-peel are examined by optical microscopy. Figure 9 shows macrograph of fracture surface of a spot weld which failed at pullout mode during coach-peel test. As can be seen, failure mechanism of the coach-peel specimens is distinctly different from that of tensile-shear specimens. Pullout failure in coach-peel test is accompanied by crack initiation and propagation. As can be seen from Figure 9 crack initiates adjacent to the notch tip, at or near the faying surface. Crack initiation site is located in the coarse grained HAZ. Final fracture occurs as the crack propagates through the sheet thickness. The observed mechanism is in agreement with mechanism



suggested by Zuniga and Sheppard [9]. They divided the failure sequence of the spot welds in the coach-peel specimens into four stages:

- I) Propagation of the notch tip toward the fusion zone,
- II) Large tensile strains at the faying surface blunt the notch tip.
- III) Ductile fracture initiation adjacent to the blunted notch tip. Crack initiation occurs by microvoid coalescence.
- IV) Final fracture occurs by crack propagation in through thickness direction.

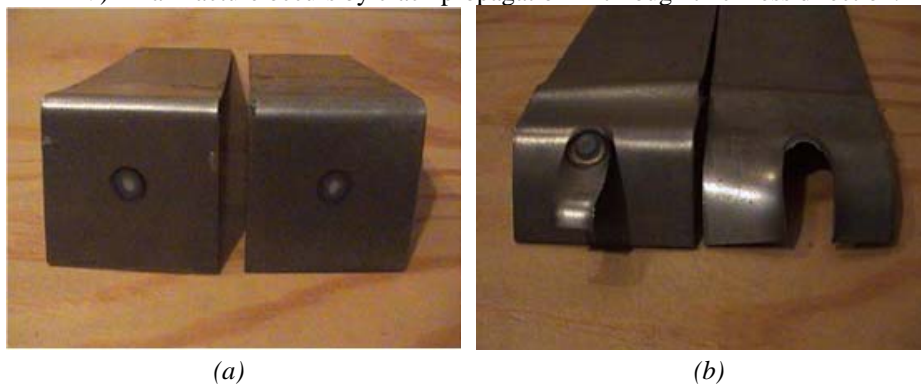

Figure 8 Failure modes of spot welds during coach-peel test a) interfacial and b) pullout failure mode

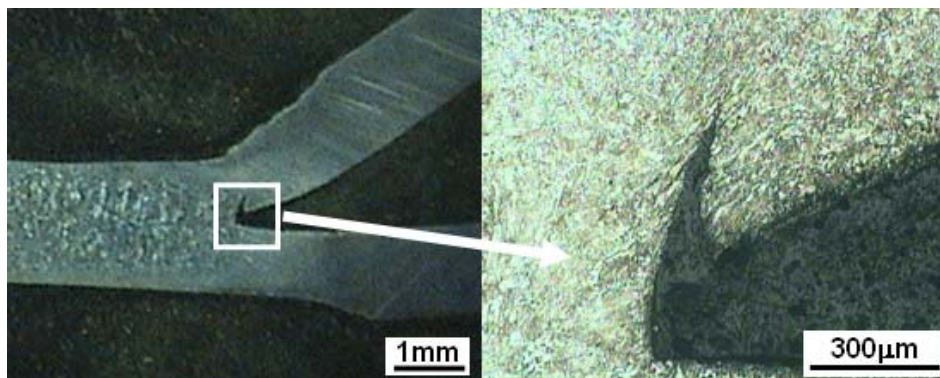

Figure 9 A typical macrograph of fracture surface cross section of spot welds which failed via pullout failure mode during coach-peel test. Welding current of this sample is 12 kA.

### Mechanical properties

Figure 10 shows relationship between weld fusion zone size and peak load in both loading condition of tensile-shear test and coach-peel test.

There is general direct relationship between fusion zone size and peak load. However, peak load in coach-peel test has low sensitivity to fusion zone size in comparison with tensile-shear test. Also, beyond a critical fusion zone size, there is no increase in coach-peel strength of the spot welds.

Load bearing capacity of spot welds under coach-peel test is much lower than that of under tensile-shear test.

Effect of fusion zone size on the failure mode of spot welds is shown in Figure 10. As can be seen in Figure 10, there is a minimum fusion zone size which beyond it spot weld tends to fail via pullout failure mode during the tensile-shear and coach-peel tests. During tensile-shear test, spot welds with fusion zone size larger than 6.1mm are failed in pullout failure mode, while, during coach-peel test, spot welds with fusion zone size larger than 5.5 mm are failed in pullout failure mode. Indeed, smaller fusion zone size requires for obtaining pullout failure mode during coach-peel test in comparison with the tensile-shear test (i.e. spot welds exhibit higher tendency to fail in interfacial failure mode during tensile-shear test rather than coach-peel test).

These above mentioned features can be related to coach-peel test configuration and its own deformation and failure characteristics.

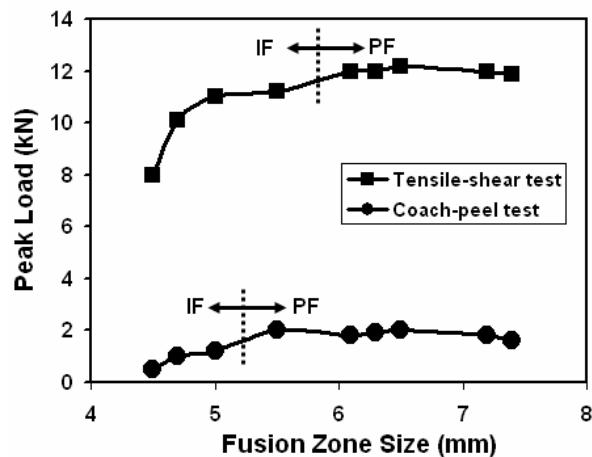

Figure 10 Effect of fusion zone size on peak load and failure mode in tensile-shear test and coach-peel test

## Conclusions

The following conclusions can be drawn from this research:

1-The coach-peel specimens in pullout failure mode failed by initiation and propagation a crack adjacent to the blunted notch tip. Tensile-shear specimens in pullout failure mode failed by through thickness necking.

2-Failure locations of coach-peel and tensile-shear specimens were in the base metal region and coarse grain HAZ, respectively.

3-There is a minimum fusion zone size to ensure pullout failure mode during mechanical testing of resistance spot welds. The critical fusion zone size to ensure pullout failure mode during tensile shear test was larger than that of during coach-peel test.



## **References**

- [1] M. Pouranvari, A. Abedi, P. Marashi, M. Goodarzi , *Sci. Technol. Weld. Joining*, 13 (2008) 39-43.
- [2] X. Sun, E. V. Stephens, M. A. Khaleel, *Eng. Fail. Anal.*, 15 (2008), 356-367.
- [3] M. Pouranvari, H. R.Asgari, S. M. Mosavizadeh, P. H. Marashi, M.Goodarzi,*Sci.Technol. Weld. Joining*, 12 (2007) 217-225.
- [4] Y. J. Chao, *Sci. Technol. Weld. Joining*, 8 (2003)133-137.
- [5] M. Marya, K.Wang, L. G. Hector, X.Gayden, *J.Manufact. Sci. Eng.*, 128 (2006), 287–298.
- [6] P.Marashi, M. Pouranvari, S. Amirabdollahian, A. Abedi, M. Goodarzi, *Mater. Sci Eng. A*, 480 (2008)175-180.
- [7] H. Zhang, J. Senkara, *Resistance welding: fundamentals and applications*, Taylor & Francis CRC press. 2005
- [8] J. E. Gould, S. P. Khurana, T. Li, *Weld J.*, 86 (2006), 111s-116s.
- [9] S. Zuniga, S. D.Sheppard: in ‘Fatigue and fracture mechanics’, Vol. 27, ASTM STP 1296, (ed. R. S. Piascik et al.), 469–489; 1997, Philadelphia, USA, ASTM.